

PENT. MOXA™ Light



PENT. MOXA™ Luxury Weighted Balls

Its excellent and prestigious design has a wide practical application. MOXA™ set are perfect as an element of modern home or hotel gym. Each ball has the same diameter - 25 cm.

Set including: 1 rack & 4 leather balls weighing:
4 kg x 1 | 8 kg x 1 | 12 kg x 1 | 16 kg x 1

DIMENSIONS

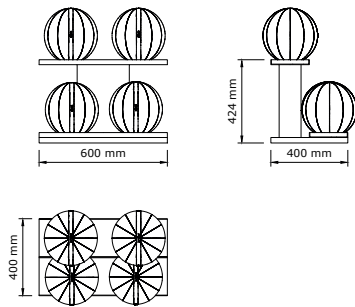

WEIGHT

NET	62 kg
GROSS	68 kg

Net = rack + leather balls
Gross = rack + leather balls + package

COLOUR & MATERIAL

WOOD

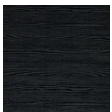

BLACK
ASH



ASH

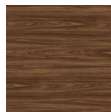

ASH
WALNUT



WALNUT



DARK
WALNUT

STEEL

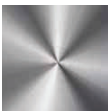

STAINLESS
STEEL

GENUINE LEATHER



BEIGE

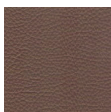

BROWN

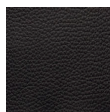

BLACK



GREY

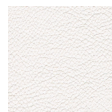

WHITE